

24-bit Sigma-Delta ADC with Gain=64 Ultra-Low-Noise Amplifier

FEATURES

Amplifier Gain: 64

Selectable Data Rates:

1.875 to 1920SPS (SIG5530A)

1.875 to 240SPS (SIG5530C)

RMS Noise: 16nV at 7.5SPS

20.4 Noise-Free Bits at 1.875SPS

Offset Drift: 5nV/°C

Gain Drift: 0.5ppm/°C

Integral Non-Linearity: 3ppm

Internal or External Clock

Burnout Current Sources

Parity Check

Power Supply

AVDD: 4.75V to 5.25V or ±2.5V

DVDD: 2.7V to 5.25V

Current: 4.0mA

Package: 20-lead TSSOP

APPLICATIONS

Weigh Scales

Strain Gauges

Pressure Sensors

Industrial Process Control

DESCRIPTION

The SIG5530A is a low noise, low drift, and high-resolution 24-bit analog-to-digital converter (ADC) with integrated gain amplifier that offers high-accuracy measurement solutions for bridge sensors.

The device contains an ultra-low-noise amplifier with fixed gain 64, a delta-sigma ($\Delta\Sigma$) modulator, and a programmable SINC3/SINC1 digital filter. For SIG5530A, the output data rate can be configured to 1.875, 3.75, 7.5, 15, 30, 60, 120, 240, 480, 960, and 1920SPS. Burnout current sources are provided at the analog inputs for sensor connection diagnosis.

Offset and gain calibration registers are provided with calibration command or direct register write to calibrate the ADC errors or overall system errors. SPI-compatible interface is used for device configuration and parity check is provided for data integrity.

The on-chip oscillator, an external clock, or an external crystal can be used as the clock source to the device.

The device can operate with bipolar $\pm 2.375V$ to $\pm 2.625V$ analog power supplies, or with a single 4.75V to 5.25V analog power supply.

The SIG5530A is available in 20-lead TSSOP package. These devices are fully specified over the $-40^{\circ}C$ to $+125^{\circ}C$ temperature range.

The SIG5530C is low cost version of SIG5530A and only supports data rate among 1.875, 3.75, 7.5, 15, 30, 60, 120, and 240SPS.

Function Block Diagram

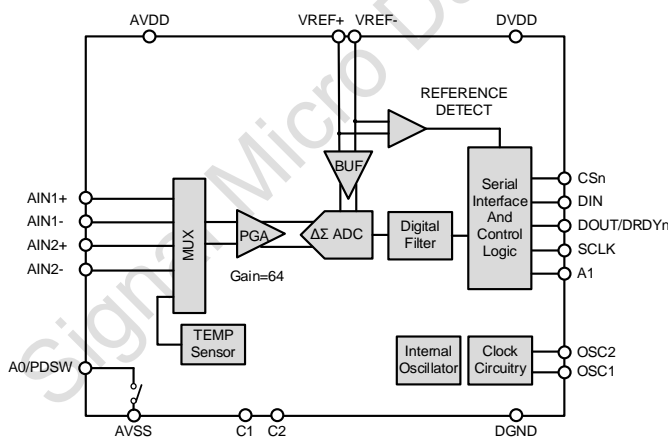

TSSOP-20

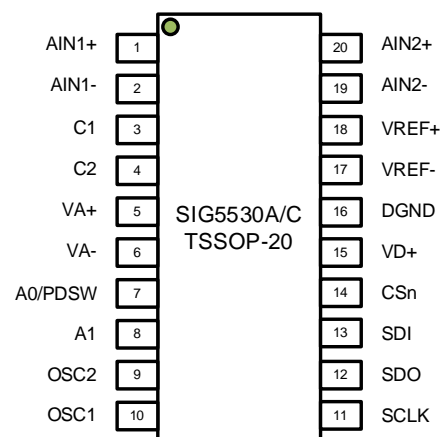

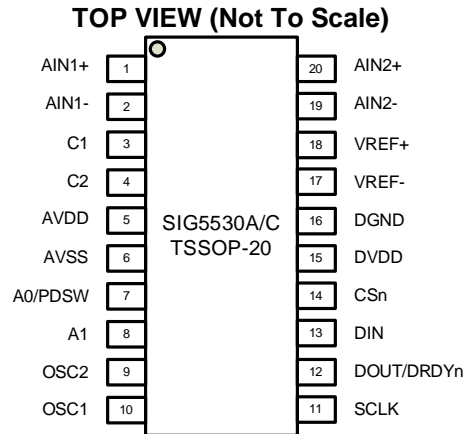
PIN CONFIGURATION and DESCRIPTIONS

PIN		FUNCTION	DESCRIPTION
No.	NAME		
1	AIN1+	Analog Input	Positive analog input channel 1.
2	AIN1-	Analog Input	Negative analog input channel 1.
3	C1	Analog Output	Amplifier analog output. Connect a COG cap with size 4.7~22nF between C1 and C2.
4	C2	Analog Output	Amplifier analog output. Connect a COG cap with size 4.7~22nF between C1 and C2.
5	AVDD	Analog	Positive analog power supply. 4.75V to 5.25V relative to AVSS.
6	AVSS	Analog	Negative analog power supply.
7	A0/PDSW	Analog Output	Analog logic output or bridge power down switch.
8	A1	Analog Output	Analog logic output.
9	OSC2	Digital Input/Output	Master clock input or Crystal Connection.
10	OSC1	Digital Input	Crystal Connection.
11	SCLK	Digital Input	Serial data clock.
12	DOUT/DRDYn	Digital Output	Serial data output and data ready indicator.
13	DIN	Digital Input	Serial data input.
14	CSn	Digital Input	Serial chip select. Active low.
15	DVDD	Digital	Digital power supply, 2.7V to 5.25V. DVDD is independent of AVDD.
16	DGND	Digital	Digital ground reference point.
17	REF-	Analog Input	Negative reference input.
18	REF+	Analog Input	Positive reference input.
19	AIN2-	Analog Input	Negative analog input channel 2.
20	AIN2+	Analog Input	Positive analog input channel 2.

PACKAGE/ORDERING INFORMATION

MODEL	PACKAGE DESCRIPTION	SPECIFIED TEMPERATURE RANGE	ORDERING NUMBER	PACKING OPTION
SIG5530A	TSSOP-20	-40°C to +125°C	SIG5530A-ITSP20-RL	Reel, 4500
SIG5530C	TSSOP-20	-40°C to +125°C	SIG5530C-ITSP20-RL	Reel, 4500

SPECIFICATIONS

Absolute Maximum Ratings

Over operating free-air temperature range, unless otherwise noted.⁽¹⁾

		MIN	MAX	UNIT
Voltage	AVDD to AVSS	-0.3	6.5	V
	AVSS to DGND	-3	0.3	V
	DVDD to DGND	-0.3	6.5	V
	Analog input	$V_{AVSS} - 0.3$	$V_{AVDD} + 0.3$	V
	Digital input	$V_{DGND} - 0.3$	$V_{DVDD} + 0.3$	V
Current	Input current	-10	10	mA
Temperature	Junction (T_J)	-50	150	°C
	Storage (T_{stg})	-60	150	°C

(1) Stresses beyond those listed under *Absolute Maximum Ratings* may cause permanent damage to the device. These is a stress rating only; functional operation of the device at these or any other conditions above those indicated in the operational section of this specification is not implied. Exposure to absolute maximum rating conditions for extended periods may affect device reliability.

ESD Ratings

SYMBOL	PARAMETER	CONDITION	VALUE	UNIT
HBM	Human-body Model	ANSI/ESDA/JEDEC JS-001	±4000	V
CDM	Charged-device model	JEDEC EIA/JS-002-2022	±2000	V



This integrated circuit can be damaged by ESD. Signal Micro recommends that all integrated circuits be handled with appropriate precautions. Failure to observe proper handling and installation procedures can cause damage. ESD damage can range from subtle performance degradation to complete device failure. Precision integrated circuits may be more susceptible to damage because very small parametric changes could cause the device not to meet its published specifications.

Electrical Characteristics

Minimum/Maximum specifications apply from -40°C to +125°C. Typical specifications are at +25°C. All specifications are at $V_{AVDD}=5V$, $V_{AVSS}=0V$, $V_{DVDD}=3.3V$, $V_{REF}=2.5V$, $f_{CLK}=4.9152MHz$, $data\ rate=60SPS$, unless otherwise noted.

PARAMETER	TEST CONDITION OR NOTES	MIN ⁽¹⁾	TYP	MAX ⁽¹⁾	UNITS
ANALOG INPUTS					
Differential Input Voltage	$V_{IN} = V_{INP} - V_{INN}$	$-V_{REF}/(2 \times Gain)$		$+V_{REF}/(2 \times Gain)$	V
Absolute Input Voltage		$V_{AVSS} + 0.5$		$V_{AVDD} - 0.5$	V
Common Mode Input Range	GAIN=64	$V_{AVSS} + 0.5 + V_{INMAX} \cdot 32$		$V_{AVDD} - 0.5 - V_{INMAX} \cdot 32$	V
Absolute Input Current			±2		nA
SYSTEM PERFORMANCE					
Amplifier Gain			64		V/V
Resolution			24		Bits
Data Rate	SIG5530A	1.875		1920	SPS
	SIG5530C	1.875		240	SPS
Noise		See Noise Table			
Integral Nonlinearity (INL)			±3		ppm
Offset Error			±3		µV
Offset Drift vs. Temperature			± 5		nV/°C
Gain Error ⁽²⁾			±0.3		%
Gain Drift vs. Temperature		-3	±0.5	3	ppm/°C
Common Mode Rejection (CMRR)	$f_{IN}=50/60Hz$, $data\ rate=960SPS$	100	120		dB
Power Supply Rejection (PSRR)	AVDD, AVSS	75	90		dB
	DVDD	80	120		dB
REFERENCE INPUT					
Differential Reference Voltage (V_{REF})	$V_{REF} = V_{REFP} - V_{REFN}$	0.5		$V_{AVDD} - V_{AVSS} + 0.1$	V
Absolute Negative Reference Voltage (V_{REFN})		$V_{AVSS} - 0.05$		$V_{REFP} - 0.5$	V
Absolute Positive Reference Voltage (V_{REFP})		$V_{REFN} + 0.5$		$V_{AVDD} + 0.05$	V
Average Voltage Input Current			300		nA
Burnout Current Sources					
Current Setting			1		µA
ADC CLOCK					
External Clock	Frequency Range	1	4.9152	5	MHz
	Duty Cycle	40%		60%	
Internal Oscillator	Nominal Frequency		4.9152		MHz
	Accuracy	-3%	±0.5%	3%	
DIGITAL INPUT/OUTPUT					
High-level Output Voltage (V_{OH})	$I_{OH} = 4mA$	$0.8 \cdot V_{DVDD}$			V
Low-level Output Voltage (V_{OL})	$I_{OL} = -4mA$			$0.2 \cdot V_{DVDD}$	V
High-level Input Voltage (V_{IH})		$0.7 \cdot V_{DVDD}$		V_{DVDD}	V
Low-level Input Voltage (V_{IL})		V_{DGND}		$0.3 \cdot V_{DVDD}$	V
Input Hysteresis			0.5		V
Input Leakage				±10	µA
POWER SUPPLY					
AVSS Voltage (V_{AVSS})		-2.625		0	V
AVDD Voltage (V_{AVDD})		$V_{AVSS} + 4.75$		$V_{AVSS} + 5.25$	V
DVDD Voltage (V_{DVDD})		2.7		5.25	V
AVDD, AVSS Current (I_{AVDD})	Active Mode		3.6	4.5	mA

	Sleep Mode		1		μA
DVDD Current (I_{DVDD})	Active Mode		0.4	0.6	mA
	Sleep Mode		40		μA
Total Power Dissipation	Active Mode		20		mW
	Sleep Mode		0.15		mW
TEMPERATURE RANGE					
Specified temperature range		-40		125	°C
Operating temperature range		-50		125	°C
Storage temperature range		-60		150	°C

- (1) Compliance to datasheet limits is assured by one or more methods: production test, characterization and/or design.
 (2) MIN and MAX values listed for gain error are for +25°C room temperature only.

Timing Requirements: Serial Interface

Over the operating ambient temperature range and DVDD = 2.7V to 5.25V, unless otherwise noted.

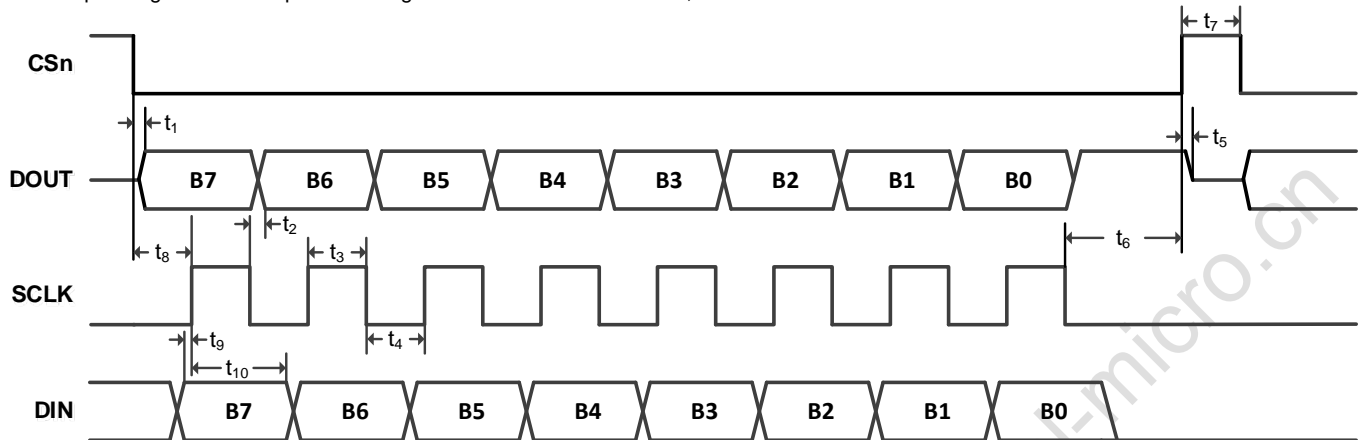

Figure 1. Serial Interface Timing Requirements

SYMBOL	DESCRIPTION	MIN	MAX	UNIT
t ₁	CSn falling edge to valid DOUT/DRDYn: propagation delay ⁽¹⁾		20	ns
t ₂	SCLK falling edge to valid DOUT/DRDYn: propagation delay ⁽¹⁾		20	ns
t ₃	SCLK high pulse width	50		ns
t ₄	SCLK low pulse width	50		ns
	SCLK period	100	10 ⁶	ns
t ₅	CSn rising edge to DOUT high impedance: propagation delay		20	ns
t ₆	Last SCLK falling edge to CSn rising edge: delay time	20		ns
t ₇	CSn high pulse width	50		ns
t ₈	CSn falling edge to first SCLK rising edge: setup time ⁽²⁾	50		ns
t ₉	Valid DIN to SCLK rising edge: setup time	20		ns
t ₁₀	Valid DIN to SCLK rising edge: hold time	20		ns

(1) DOUT load = 20pF || 100kΩ to DGND.

(2) CSn can be tied low.

NOISE PERFORMANCE

The noise performance of the ADC is affected by amplifier gain, data rate, and digital filter setting. The following tables show the rms noise and peak-to-peak noise for SINC3 and SINC1 filters. The effective number of bits (ENOB) and noise-free bits are also listed according to Equation (1) and Equation (2):

$$\text{ENOB} = \log_2(2 \times V_{\text{REF}} / \text{Gain} / V_{\text{RMS}}) \quad (1)$$

$$\text{Noise Free Bits} = \log_2(2 \times V_{\text{REF}} / \text{Gain} / V_{\text{p-p}}) \quad (2)$$

The noise data listed in the table are typical and are generated from continuous ADC readings with differential input voltage of 0 V.

Table 1. ADC Noise in μVRMS (μVPP) at $T_A = 25^\circ\text{C}$, $V_{\text{AVDD}} = 5\text{ V}$, $V_{\text{AVSS}} = 0\text{ V}$, $V_{\text{REF}} = 2.5\text{ V}$, SINC3 Filter

Data Rate(SPS)	GAIN=64
1.875	0.008(0.050)
3.75	0.011(0.070)
7.5	0.016(0.099)
15	0.023(0.140)
30	0.032(0.198)
60	0.045(0.280)
120	0.064(0.396)
240	0.091(0.561)
480	0.128(0.793)
960	0.182(1.12)
1920	0.255(1.55)

Table 2. ADC ENOB (Noise Free Bits) at $T_A = 25^\circ\text{C}$, $V_{\text{AVDD}} = 5\text{ V}$, $V_{\text{AVSS}} = 0\text{ V}$, $V_{\text{REF}} = 5\text{ V}$, SINC3 Filter

Data Rate(SPS)	GAIN=64
1.875	23.2(20.4)
3.75	22.7(19.9)
7.5	22.2(19.4)
15	21.7(18.9)
30	21.2(18.4)
60	20.7(17.9)
120	20.2(17.4)
240	19.7(16.9)
480	19.2(16.4)
960	18.7(15.9)
1920	18.2(15.3)

Table 3. ADC Noise in μVRMS (μVPP) at $T_A = 25^\circ\text{C}$, $V_{\text{AVDD}} = 5\text{ V}$, $V_{\text{AVSS}} = 0\text{ V}$, $V_{\text{REF}} = 2.5\text{ V}$, SINC1 Filter

Data Rate(SPS)	GAIN=64
1.875	0.010(0.062)
3.75	0.014(0.088)
7.5	0.020(0.125)
15	0.029(0.176)
30	0.041(0.249)
60	0.057(0.352)
120	0.081(0.498)
240	0.115(0.705)
480	0.163(0.996)
960	0.230(1.41)
1920	0.317(2.20)

Table 4. ADC ENOB (Noise Free Bits) at $T_A = 25^\circ\text{C}$, $V_{\text{AVDD}} = 5\text{ V}$, $V_{\text{AVSS}} = 0\text{ V}$, $V_{\text{REF}} = 5\text{ V}$, SINC1 Filter

Data Rate(SPS)	GAIN=64
1.875	22.8(20.1)
3.75	22.3(19.6)
7.5	21.8(19.1)
15	21.3(18.6)
30	20.8(18.1)
60	20.3(17.6)
120	19.8(17.1)
240	19.3(16.6)
480	18.8(16.1)
960	18.3(15.6)
1920	17.9(15.0)

REGISTER MAPS

There are total three 32-bit registers inside the device. These registers are used to configure and control the ADC to the desired mode of operation. These registers can be accessed through the SPI-compatible serial interface by using register read and write commands. At power-on or reset, the registers default to their initial settings, as shown in the *Reset Value* column of [Table 5](#).

Table 5. Register map

ADDR. RS[2:0]	NAME	RESET VALUE	BIT 31	BIT 30	BIT 29	BIT 28	BIT 27	BIT 26	BIT 25	BIT 24
			BIT 23	BIT 22	BIT 21	BIT 20	BIT 19	BIT 18	BIT 17	BIT 16
			BIT 15	BIT 14	BIT 13	BIT 12	BIT 11	BIT 10	BIT 9	BIT 8
			BIT 7	BIT 6	BIT 5	BIT 4	BIT 3	BIT 2	BIT 1	BIT 0
3'b001	OFFSET	0x00000000	OFFSET[31:24]							
			OFFSET[23:16]							
			OFFSET[15:8]							
			OFFSET[7:0]							
3'b010	GAIN	0x01000000	GAIN[23:16]							
			GAIN[15:8]							
			GAIN[7:0]							
			PSS	PDW	RS	RV	SHORT	A0_PSW	VRS	A1
3'b011	CONF	0x00000000	A0	0	0	0	FRS	FILTER	TPS	0
			0	DR[3]	DR[2]	DR[1]	DR[0]	FORMAT	BCS	DT
			CHKSUM	LATENCY	CLK1	CLK0	CS1	CS[0]	0	0

OFFSET Register

Table 6. OFFSET Register (Address = 3'b001)

BIT 31	BIT 30	BIT 29	BIT 28	BIT 27	BIT 26	BIT 25	BIT 24
BIT 23	BIT 22	BIT 21	BIT 20	BIT 19	BIT 18	BIT 17	BIT 16
BIT 15	BIT 14	BIT 13	BIT 12	BIT 11	BIT 10	BIT 9	BIT 8
BIT 7	BIT 6	BIT 5	BIT 4	BIT 3	BIT 2	BIT 1	BIT 0
OFFSET[31]	OFFSET[30]	OFFSET[29]	OFFSET[28]	OFFSET[27]	OFFSET[26]	OFFSET[25]	OFFSET[24]
OFFSET[23]	OFFSET[22]	OFFSET[21]	OFFSET[20]	OFFSET[19]	OFFSET[18]	OFFSET[17]	OFFSET[16]
OFFSET[15]	OFFSET[14]	OFFSET[13]	OFFSET[12]	OFFSET[11]	OFFSET[10]	OFFSET[9]	OFFSET[8]
OFFSET[7]	OFFSET[6]	OFFSET[5]	OFFSET[4]	OFFSET[3]	OFFSET[2]	OFFSET[1]	OFFSET[0]

Power-On/Reset value = 0x00000000

Bits	Bit Name	Access	Reset	Description
31:0	OFFSET[31:0]	R/W	0x00000000	Offset Calibration Bits: The 32-bit word is signed number in 2's complement format. See Calibration section for more information.

GAIN Register

Table 7. GAIN Register (Address = 3'b010)

BIT 31	BIT 30	BIT 29	BIT 28	BIT 27	BIT 26	BIT 25	BIT 24
BIT 23	BIT 22	BIT 21	BIT 20	BIT 19	BIT 18	BIT 17	BIT 16
BIT 15	BIT 14	BIT 13	BIT 12	BIT 11	BIT 10	BIT 9	BIT 8
BIT 7	BIT 6	BIT 5	BIT 4	BIT 3	BIT 2	BIT 1	BIT 0
GAIN[31]	GAIN[30]	GAIN[29]	GAIN[28]	GAIN[27]	GAIN[26]	GAIN[25]	GAIN[24]
GAIN[23]	GAIN[22]	GAIN[21]	GAIN[20]	GAIN[19]	GAIN[18]	GAIN[17]	GAIN[16]
GAIN[15]	GAIN[14]	GAIN[13]	GAIN[12]	GAIN[11]	GAIN[10]	GAIN[9]	GAIN[8]
GAIN[7]	GAIN[6]	GAIN[5]	GAIN[4]	GAIN[3]	GAIN[2]	GAIN[1]	GAIN[0]

Power-On/Reset value = 0x01000000

Bits	Bit Name	Access	Reset	Description
31:0	GAIN[31:0]	R/W	0x01000000	Gain Calibration Bits: The 32-bit word is unsigned positive number in binary format. See Calibration section for more information.

Configuration Register (CONF)

Table 8. CONF Register (Address = 3'b011)

BIT 31	BIT 30	BIT 29	BIT 28	BIT 27	BIT26	BIT 25	BIT 24
BIT 23	BIT 22	BIT 21	BIT 20	BIT 19	BIT18	BIT 17	BIT 16
BIT 15	BIT 14	BIT 13	BIT 12	BIT 11	BIT10	BIT 9	BIT 8
BIT 7	BIT 6	BIT 5	BIT 4	BIT 3	BIT 2	BIT 1	BIT 0
PSS	PDW	RS	RV	SHORT	A0_PSW	VRS	A1
A0	0	0	0	FRS	FILTER	TPS	0
0	DR[3]	DR[2]	DR[1]	DR[0]	FORMAT	BCS	DT
CHKSUM	LATENCY	CLK1	CLK0	CS1]	CS[0]	0	0

Power-On/Reset value = 0x00000000

Bits	Bit Name	Access	Reset	Description
31	PSS	R/W	1'b0	Power Save Select: 0: Standby Mode (default) 1: Sleep Mode
30	PDW	R/W	1'b0	Power Down Mode: 0: Normal Mode (default) 1: Power Down Mode
29	RS	R/W	1'b0	Reset System: 0: Normal Operation (default) 1: Activate a Reset cycle.
28	RV	R	1'bx	Reset Indicator: Read only. Bit is cleared to logic zero after the CONF register is read. 0: Normal Operation (default) 1: System was reset.
27	SHORT	R/W	1'b0	Input Short: 0: Normal Input (default) 1: Analog Inputs are disconnected from the pins and shorted internally to mid-supply ($V_{AVDD}+V_{AVSS}$)/2.
26	A0_PSW	R/W	1'b0	Bridge Power-down Switch Function: When this bit is set to 1, the output latch bit A0 is served as the switch control bit. The switch is closed to short pin A0 to DVSS with low on-resistor of typical 3 Ohms if the output latch bit is set to 1. The switch is open if the output latch bit is cleared. The switch remains active in standby mode and is forced to open in sleep mode. 0: Disabled (default) 1: Enabled.
25	VRS	R/W	1'b0	Voltage Reference Select: The input full-scale range is $[-V_{REF}/(2 \times \text{gain}), V_{REF}/(2 \times \text{gain})]$ with VRS=0, and is $[-V_{REF}/\text{gain}, V_{REF}/\text{gain}]$ with VRS=1. 0: $2.5V < V_{REF} < (V_{AVDD} - V_{AVSS})$ (default) 1: $0.5V < V_{REF} < 2.5V$
24	A1	R/W	1'b0	Output Latch Bit: This bit sets the value of the A1 output pin. During register read, this bit reflects the status of the A1 pin. 0: AVSS (default) 1: AVDD

23	A0	R/W	1'b0	Output Latch Bit: This bit sets the value of the A0 output pin. During register read, this bit reflects the status of the A0 pin. 0: AVSS (default) 1: AVDD
22:20	RESERVED	R/W	3'b000	Reserved Always write 3'b000
19	FRS	R/W	1'b0	Filter Rate Select: 0: Default output data rates. (default) 1: Scale the output data rate by a factor of 5/6.
18	FILTER	R/W	1'b1	Digital Filter Configuration: Configures the ADC digital filter 0: SINC5/SINC3 filter (default) 1: SINC5/SINC1 filter
17	TPS	R/W	1'b0	Temperature Sensor Enable Bit: The voltage output is about 125.4mV at room temp and the rate of change over temperature is about 420uV/°C. Amplifier gain is internally forced to 1 with buffer on for temperature sensor measurement. 0: Disabled (default) 1: Enabled.
16:15	RESERVED	R/W	2'b00	Reserved Always write 2'b00
14:11	DR[3:0]	R/W	4'b0000	Data Rate Configuration: Selects the ADC data rate. 0000: 120SPS (default) 0001: 60SPS 0010: 30SPS 0011: 15SPS 0100: 7.5SPS 1001: 1920SPS (SIG5530A only) 1010: 960SPS (SIG5530A only) 1011: 480SPS (SIG5530A only) 1100: 240SPS 1101: 3.75SPS 1110: 1.875SPS
10	FORMAT	R/W	1'b0	Data Format Bit: This bit sets the ADC data format. 0: Bipolar mode (default) 1: Unipolar mode
9	BCS	R/W	1'b0	Burnout Current Sources: 1µA of current source is added to the input channel if enabled. 0: Disabled (default) 1: Enabled
8	DT	R/W	1'b0	Delay Time Bit: When set, the converter will wait for a delay time before starting a conversion. The delay time is 1280 SYSCLK cycles when FRS=0. And 1536 SYSCLK cycles when FRS=1. 0: No delay (default) 1: Delay time added
7	CHKSUM	R/W	1'b0	ADC Data Checksum Enable Bit: 0: Disabled (default) 1: Enabled
6	LATENCY	R/W	1'b0	Zero Latency Bit: When this bit is set, the ADC settles in one conversion cycle so that it functions as a zero latency ADC.
5:4	CLK[1:0]	R/W	2'b00	Clock Select Bits: These bits select the clock source for SYSCLK. 00: External crystal applied between OSC1 and OSC2. (default) 01: External clock applied to the OSC2 pin.

				10: Internal 4.9152MHz clock with OSC2 tristated. 11: Internal 4.9152MHz clock with its output on OSC2 pin.
3:2	CS[1:0]	R/W	2'b00	Channel Select Bits: 00: Select physical channel 1: AIN1+/AIN1- (default) 01: Select physical channel 2: AIN2+/AIN2- 10: Reserved 11: Reserved
1:0	RESERVED	R/W	2'b00	Reserved Always write 2'b00

Signal Micro Datasheet @ www.signal-micro.cn

REVISION HISTORY

The revision history provided is for informational purposes only and is believed to be accurate, but not warranted. Please go to web to make sure you have the latest revision.

DATE	REVISION	CHANGE
May 20, 2022		Initial release.

DISCLAIMER

Signal Micro reserves the right to make any change in circuit design, specification or other related things if necessary without notice at any time.

All trademarks and registered trademarks are the property of their respective owners.

PACKAGE OUTLINE DIMENSIONS

TSSOP-20

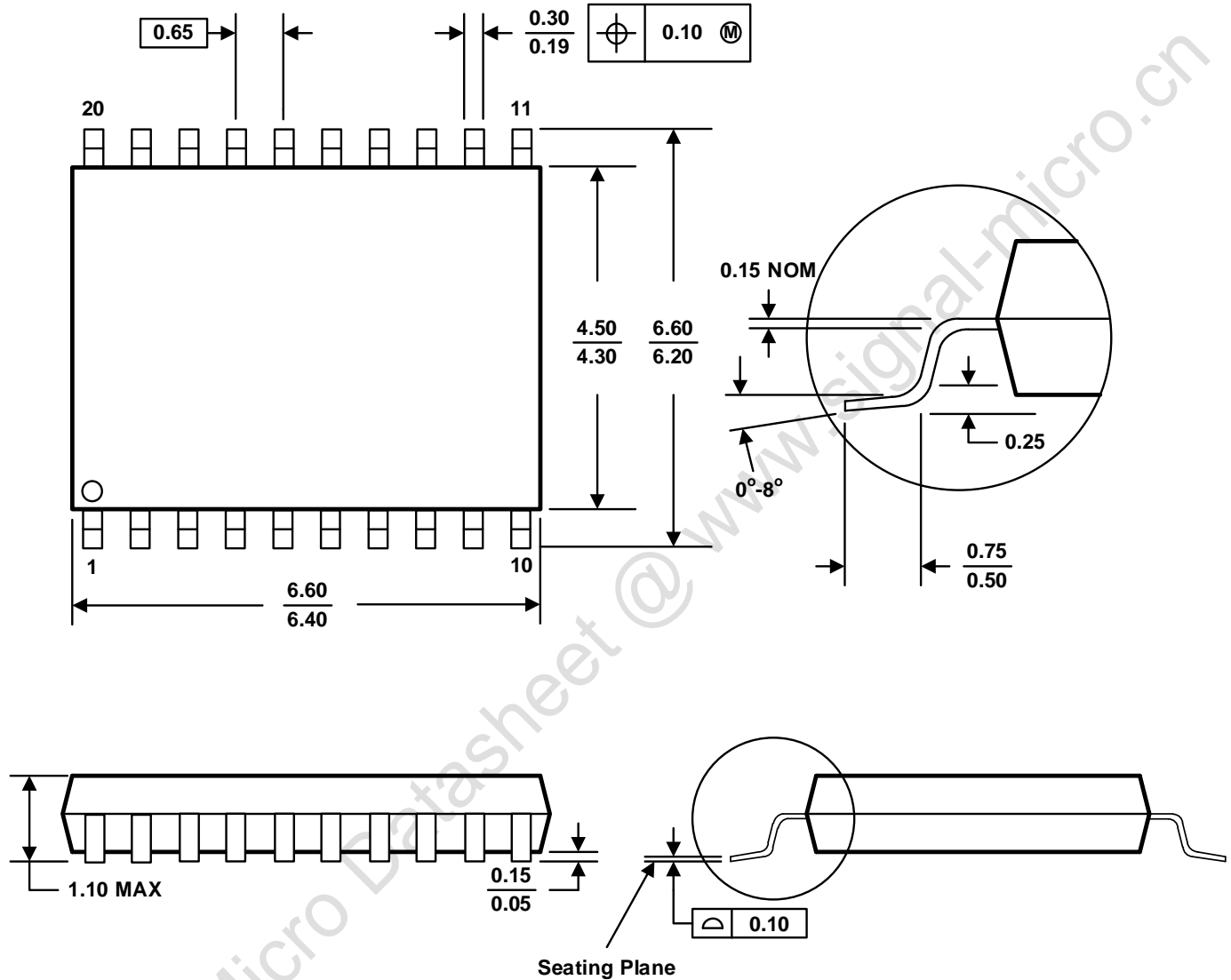

- A. Compliant to JEDEC STANDARDS MO-153-AD.
- B. All linear dimensions are in millimeters.
- C. This drawing is subject to change without notice.